

51 - 57 hp Hedge and Grass Cutters



[www.kuhn.com](http://www.kuhn.com)

**POLY-LONGER**  
**MULTI-LONGER GII**



be strong, **be KUHN**







**POLY-LONGER**

5050 P

5050 SP

5050 PA

5050 SPA

**MULTI-LONGER GII**

5057 P

5557 P

5557 SP

5757 SPA

# A MACHINE FOR EVERY NEED



KUHN has developed POLY-LONGER and MULTI-LONGER GII hedge and grass cutter models that can be operated for 500 to 800 hours per year.

The POLY-LONGER models were designed to be extremely versatile and are intended for individual use or for small groups of users.

The MULTI-LONGER GII models are better suited to cooperative farming applications and city services, thanks to their structure and their power.

Available in 4 different kinematics and 2 rotor power levels, there is sure to be a POLY-LONGER or MULTI-LONGER GII model that meets your needs:

- Straight arm
- OPTiView semi-leading arm
- Straight arm with parallelogram kinematics,
- OPTiView semi-leading mounted arm with parallelogram kinematics.

With their quality construction and high-performance components, they offer the guarantee of a quality result for many years!

POLY-LONGER models can easily be operated for up to 500 hours per year, and 800 hours for the MULTI-LONGER GII models.

All POLY-LONGER and MULTI-LONGER GII models feature the EP proportional control system as standard, making the machines easier to drive.

The 116° pivot will be appreciated for its rear slewing ability in dead-end paths or to quickly negotiate obstacles.



POLY-LONGER models	Horizontal reach (m)	Power (kW/hp)	Kinematics
5050 P	5.00	37/51	Straight arm
5050 SP	5.00	37/51	OPTiView semi-leading arm
5050 PA	5.00	37/51	Straight arm on parallelogram
5050 SPA	5.00	37/51	OPTiView semi-leading arm on parallelogram

MULTI-LONGER GII Models	Horizontal reach (m)	Power (kW/hp)	Kinematics
5057 P	5.00	41/57	Straight arm
5557 P	5.50	41/57	Straight arm
5557 SP	5.50	41/57	OPTiView semi-leading arm
5757 SPA	5.70	41/57	OPTiView semi-leading arm on parallelogram





## EP CONTROL:

### 4 ELECTRIC PROPORTIONAL FUNCTIONS AS STANDARD!

The POLY-LONGER and MULTI-LONGER GII hedge and grass cutters are controlled via 4 electric proportional functions: Pivot, main and outer booms and head orientation. The more often you move the joystick in a direction, the faster the component you're controlling moves. The control system is flexible and precise, your driving comfort is unsurpassed.

For greater safety and precision, the proportional effect works in both directions: up and down. No matter where you are working, (shoulder, slope, ditch, hedge, etc.), precision is your best friend.

For efficiency, the functions of the main and outer boom, and orientation of the cutting tool, pivot and head can be activated simultaneously with the ergonomic joystick and the various buttons. The EP joystick can also be adjusted to fit your hand size.

The EP joystick is easy to install even in the smallest cabs. It is connected to the machine by a single small-diameter electric cable.

The T15 unit can be separated from the main control panel to fit all cab layouts. You can easily place it at eye level and/or within easy reach.



# THE EP JOYSTICK

TURNS YOU INTO A PROFESSIONAL DRIVER  
THE MINUTE YOU START

**KUHN** **Electronics**  
INNOVATIVE FARMING



## T15 CONTROL CONSOLE

The unit can be detached from the main control panel, and includes many features:

- Hour meter and oil temperature display,
- Control the lift, the automatic arm break-back and the rotor ("grass" or "branches" rotor control) with anti-reverse safety,
- Indicator lights, fan, float and temperature alert, floating flail head.

The console also includes a diagnostic and troubleshooting mode to keep your machine in perfect working order.





# VERSATILE

When you invest in a 51 or 57 hp hedge and grass cutter with a range of 5 to 5.70 m, you basically want a machine that can go anywhere. The POLY-LONGER and MULTH-LONGER GII models have been designed with this in mind.

Whether you're working alone along a field, river or forest or performing roadside maintenance for the city, the kinematics of the POLY-LONGER and MULTH-LONGER GII models are exactly what you need.

## QUICK SET-UP

The many coupling solutions and easy cab installation make it faster to prepare the machine and uncouple it from the tractor.

## GOES ANYWHERE!

The pivot for the slewing action, the vertical range up to 6.86 m, the parallelogram-mounted and/or OPTIview semi-leading arm and accessories such as the SRS (Shift Rail System) are all high-tech advantages when it comes to landscape and roadside maintenance. What used to be hard work is now a snap!







### SAFE TRANSPORT MODE

During transport, the arm position is no wider than the tractor outline. You can drive on the road safely, without endangering yourself or other drivers.



### SAFETY BREAK-BACK

When the arm encounters an obstacle, it retracts automatically. This prevents breakage and deformations.



### EASY ACCESS

The arm pivots hydraulically with 116° angle. You can mow in areas with no outlet without moving the tractor. You can also negotiate obstacles without moving the tractor.



### OVER THE TOP

The cylinder of the outer boom is positioned above the arm so you can work over the top of fences or hedges without snagging. The parallelogram models can reach over even higher fences due to the anchor point of the arm on the rocker.



### REACH FAR!

With horizontal reach from 5.00 to 5.70 m, the POLY-LONGER and MULTHLONGER GII models work easily on wide hedgerows, distant slopes and on both sides of rivers. On tall embankments and deep canals, the large clearance under the arm and the "deep ditch" reach of 3.63 m will make your work easy and safe.



### REACH HIGH!

The vertical reach of up to 6.86 m means that your machines will be able to work close to the hedges without snagging. A "hydraulic anti-tipping" system automatically manages the centre of gravity of the arm to avoid the risk of overturning.



### THE PARALLELOGRAM MAKES ALL THE DIFFERENCE!

The PA and SPA models feature parallelogram kinematics. One joystick movement adjusts the movements of the main boom and outer boom simultaneously. This makes it easier to negotiate obstacles on verges and above hedgerows.



### NARROW PATHS

The centred pivot on the POLY-LONGER and MULTHLONGER GII models and their kinematics make it possible to work on narrow paths. When you work on the vertical plane close to the tractor, the arm doesn't extend onto the opposite side.



### HEAD ROTATES 220° AND 240°

The cutting tool joint is positioned at the rear of the tool to ensure a wide range of motion even when the arm is extended to its maximum vertical or horizontal reach.

# EQUIPMENTS WORTHY OF PRO MACHINES

Your new POLY-LONGER or MULTI-LONGER GII hedge and grass cutter will make you quickly forget your old machine! These two ranges feature equipment designed for comfort and performance as standard on all models.

Whether you are an individual farmer, a member of a cooperative, a contractor or a city manager, you will be totally satisfied.

With their robust construction and structural design, the trim level and the wide choice of coupling and cutting equipment, the POLY-LONGER and MULTI-LONGER GII models will be your best friends.

The POLY-LONGER and MULTI-LONGER GII models have gear circuits, for the best compromise between performance, reliability, easy servicing and maintenance cost.



## DESIGNED TO LAST!

The arm is designed based on a reconstituted structure. This construction offers many advantages including reduced steel thicknesses and additional internal reinforcements on the parts of the arm subjected to heavy stress **1**.

The very high yield strength (VHYS) steel used provides twice the strength **2** and flexibility as a conventional tubular structure.

VHYS steel has shape memory. Depending on the level of strain, the steel returns to its original position, so it is less likely to break after a repeated strain **A**. Aging, reflected by the breaking point, is delayed **B**.

All the joints are mounted on bi-metal wear bushings with grease reservoir. Shaft rotation is limited to prevent premature wear.

**Strength\***  
**X2**

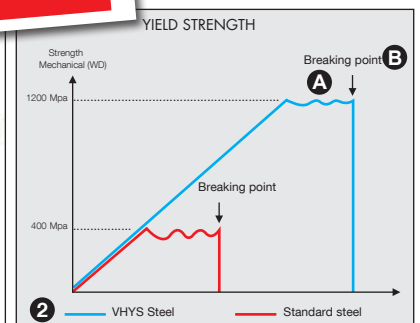
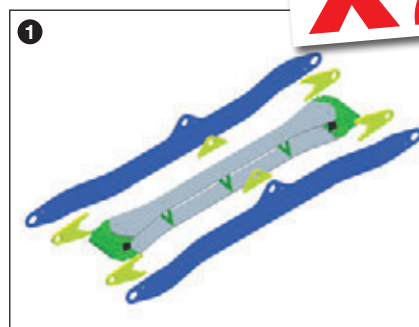

\* Strength compared to a tubular structure made with standard steel





### TOTAL PROTECTION

In addition to looking good, the full enclosure ensures total protection of all hydraulic components of your POLY-LONGER and MULTHLONGER GII.

Soiling is kept to a strict minimum. The inclined surface of the lower part of the frame provides high clearance for travelling over rough terrain. The lighting built in to the bumper is standard on all POLY-LONGER and MULTHLONGER GII models.

### HOSES: CAREFUL ROUTING AND AUTOMATIC GUIDING!

The hydraulic lines use a "100% flexible" solution, making them less sensitive to falling plant debris. This is also the least expensive and fastest solution when it comes to maintenance and repairs.

The main and outer booms have protective housings and sheaths all the way to the cutting tool.

A swivelling plate at the pivot automatically guides the hoses with respect to the arm movements to eliminate hose friction.

### OVERSIZED RADIATOR

The cooling capacity of the powerful fans on the POLY-LONGER and MULTHLONGER GII models guarantees that you can work all day long.

They deliver an output of 12 kW. The low temperature fan tripping threshold prevents thermal runaway of the hydraulics. Positioned on the left side and not at the rear, the fan draws in much less dust raised by the tractor wheel.



Exchange capacity  
**+30%\***

\* Exchange capacity measured compared to equivalent models available on the market



# THE POLY-LONGER RANGE

## POLY-LONGER 5050 P

### THE BEST COMPROMISE BETWEEN PERFORMANCE AND COST

The POLY-LONGER 5050 P features a straight arm with compass movement. With a horizontal reach of 5.00 m, this hedge and grass cutter is ideal for agricultural use on embankments and ditches. Like all other models in the POLY-LONGER range, the 5050 P model features the EP (4-function electric proportional) control system as standard, as well as the pivot with a 116° slew angle and a 1.20 m flail head driven by two cog-type V-belts.



## POLY-LONGER 5050 SP

### OPTiView: BETTER VISIBILITY

The POLY-LONGER 5050 SP features the same technical characteristics as the 5050 P version with the added benefit of the OPTiView semi-leading arm. The arm is offset 985 mm forward (distance between the rotor axis and the coupling axis to the tractor ball joints), facilitating visibility and working comfort.

You will be able to better anticipate and negotiate obstacles.





**POLY-LONGER**

**5050 PA**

### THE PARALLELOGRAM: THE AUTOMATIC TRANSMISSION OF YOUR HEDGE AND GRASS CUTTER!

The main and outer booms of the POLY-LONGER 5050 PA model are linked by a mechanical rod. A single movement on the joystick activates two arm movements. This offers several advantages when it comes to driving the machine and controlling costs:

- More flexibility during movements,
- Less fatigue for the operator,
- Faster negotiation of obstacles,
- Lower maintenance costs by reducing friction (less pressure on the ground).



**POLY-LONGER**

**5050 SPA**

### SUPERIOR COMFORT!

The POLY-LONGER 5050 SPA presents real advantages for roadside maintenance professionals. The enhanced visibility, thanks to the 985 mm offset OPTIview semi-leading arm (distance between the rotor axis and the coupling axis to the tractor ball joints), will be appreciated by anyone who routinely clears brush and hedgerows. Roadside maintenance workers will also appreciate all the benefits provided by the kinematics parallelogram-mounted arm.





# THE MULTI-LONGER GII RANGE

**MULTI-LONGER GII**

**5057 P**

## STRAIGHT ARM KINEMATIC POWER

The MULTH-LONGER GII is a machine for anyone looking for a compact machine with a horizontal reach of 5.00 m and a 57 hp system to power a "thick wood" rotor. Thanks to its compact size, it can work in hedgerow areas where the paths are narrow. Like all models in the MULTH-LONGER GII range, the 5057 P model features the EP (4-function electric proportional) control system as standard, making it intuitive and comfortable to use.



**MULTI-LONGER GII**

**5557 P**

## STRAIGHT ARM WITH MORE REACH!

The MULTH-LONGER GII 5557 P has the same features and benefits as the 5057 P version: 57 hp, EP control SYSTEM, structure totally reconstituted in VHYS and 116° pivot, while providing more horizontal reach (5.50 m). It is perfect for specific jobs requiring a longer arm such as canals or deep ditches. Like all MULTH-LONGER GII models, the 5557 P version features a belt-driven 1.20 m cutting head.





## MULTI-LONGER GII

5557 SP

### VISIBILITY AND PERFORMANCE

The MULTH-LONGER GII SP model features the OPTIview semi-leading arm. The geometry of the outer boom allows the operator to always keep an eye on the cutting tool without having to turn around. The arm is offset 985 mm forward (distance between the rotor axis and the coupling axis to the tractor ball joints).

As with all OPTIview kinematics where the cutting tool is at the same height as the driver (depending on the tractor make and model), it will be easier to see and avoid obstacles.



## MULTI-LONGER GII

5757 SPA

### WELCOME TO THE PROFESSIONAL CATEGORY!

Based on the performance of the MULTH-LONGER GII range with its 57 hp, the 5757 SPA model offers the advantage of even more horizontal reach, namely 5.70 m. The MULTH-LONGER GII 5757 SPA has been designed to meet the needs of all maintenance professionals (city services, agricultural contractors, etc.), with OPTIview semi-leading arm kinematics and parallelogram-mounted arm kinematics. The parallelogram is easy to control and provides added visibility. The main and outer booms are linked by a mechanical rod, so the operator can control the movement of the entire arm with just a single joystick movement.





# PERSONALIZE YOUR KUHN HEDGE AND GRASS CUTTER

## GET HITCHED!

Whether you need to couple and uncouple frequently or occasionally, our engineers redesigned this often delicate and difficult operation.

To facilitate coupling, the EP (electric proportional) joystick control system is now standard on all POLY-LONGER and MULTI-LONGER GII models. It has a small footprint and requires just one wiring harness to connect it to the machine, making it easy to install in the cab.

### KIT STABILISERS

The two stabilisers with universal joints are fitted as standard on the POLY-LONGER and MULTI-LONGER GII ranges. Installed on the top link bracket, they ensure the stability of the assembly.

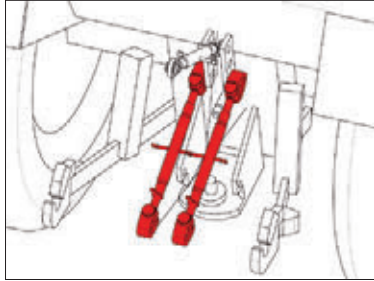

### KIT COUPLING LUGS

The system is composed of hitching lugs with swivel-joint stabilisers, and attaches to the couple bracket. By increasing the distance between the anchor points of the two stabilisers, this solution offers good tractor/machine stability.

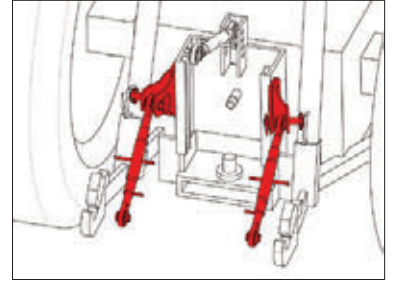

### KIT COUPLING FRAME

Like the "hitching lugs" kit, the frame is based on the 3-point couple principle. It consists of two swivel-joint stabilisers positioned on a horizontal support bar. This increases the distance between the anchor points of the two stabilisers at the top link bracket, improving the rigidity and stability of the assembly for machines with very long reaches.

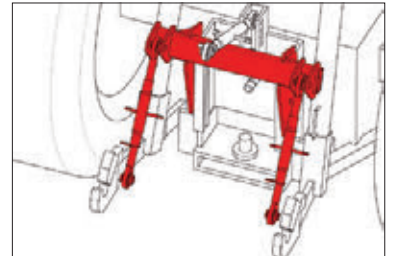

# KUHN ADVANTAGES

## STABI-LINK

**COUPLE AND UNCOUPLE YOUR TRACTOR IN 5 MINUTES!**

For all users who want to maximize tractor stability while quickly making it available for other work, the STABI-LINK is the ideal solution.

Where other chassis require significant changes to the tractor linkage to achieve good stability, the STABI-LINK can be fitted and removed in double-quick time.

The STABI-LINK fits on the tractor lift and automatically attaches to the hitch supports mounted on the tractor axle tubes. Once mounted on the tractor axle tubes, the yoke joint supports remain in place even when coupling your other machines.

Installation is quick, safe and above all effortless!

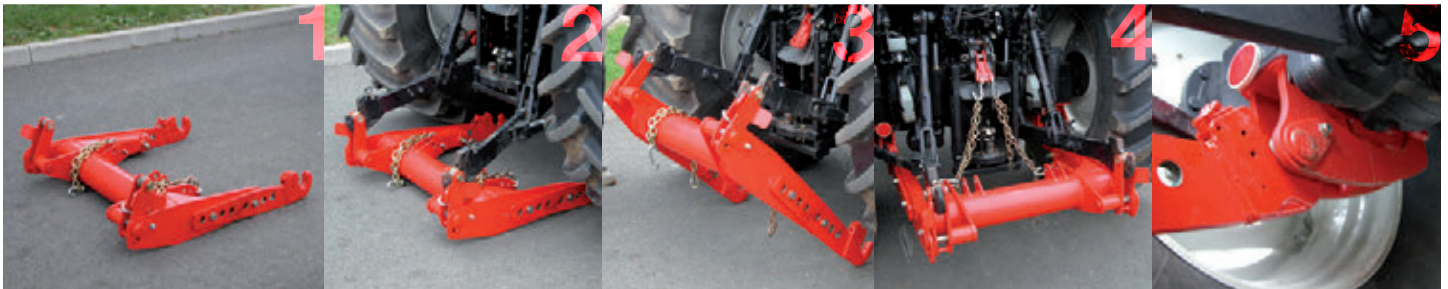
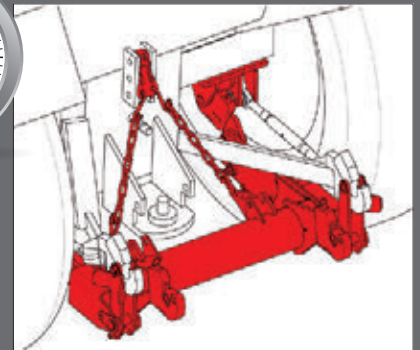

TO LEARN MORE ABOUT THE STABI-LINK SYSTEM,  
scan this QRCode with your smartphone or visit the website [www.kuhn.com](http://www.kuhn.com) and click on "Product Range".



# MODIFY YOUR MACHINE FOR DIFFERENT JOBS

Will you be working on a number of different jobs? That's no problem with the POLY-LONGER and MULTH-LONGER GII ranges, which have 51 and 57 hp systems powering the rotor circuit! All the models in the range can accommodate a wide range of cutting tools. From mowing infiltration strips to clearing brush, from hedge maintenance to tree pruning, the cutting tools are designed to support your machine performance in all situations.

## 1.20 M HEAD: CUTTING QUALITY AND SPEED

The head is driven by two cog-type V-belts with a simple and reliable design. The rounded profile of the head helps your machine work effectively on ditch bottoms or over rough terrain ❶.

The KUHN cutting head rotors are reversible so you can optimise wear on the flails and lugs simply by turning them around ❷. To reduce maintenance costs, the head also comes with a removable wear plate.

All POLY-LONGER and MULTH-LONGER GII models are equipped with the 140 mm diameter PRO series sensor roller, designed with removable ends requiring no lubrication to ensure a long lifespan.

For sustained work, there is the 140 mm diameter XTREM version sensor roller, featuring a superior bearing and sealing system. The bearings are protected by oil-film lubricated face seals, guaranteeing long hours of work.

Finally, you can easily change the cutting tool thanks to the semi-automatic coupling system.



## SHIFT RAIL SYSTEM (SRS)

SRS is a system that allows the head to slide +/- 40 cm along the arm, increasing the horizontal reach by the same amount. It also facilitates access under and behind fences or barbed wire ❸.

The 90° head rotation also helps when mowing in narrow paths or behind the tractor wheel ❹.

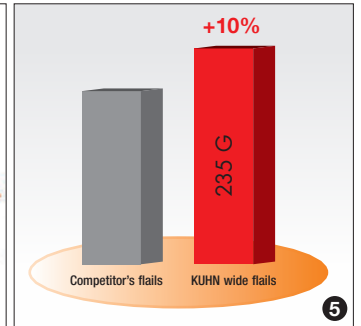
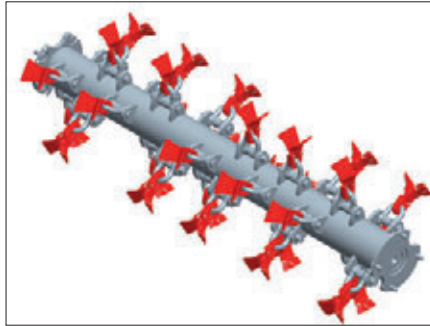

## UNIVERSAL ROTOR

The universal rotor is equipped with 60 Y-flails mounted on 14 mm shackles and can cut through scrub up to 3 cm thick.

You will not regret choosing KUHN brand flails! The exclusive KUHN wide Y-flails are 10% heavier ❺, which means they wear more slowly, and have higher hardness than what's available on the market: 50 HRC.

The shackle eyelets are reinforced to be 10 mm thicker, increasing the contact surface between the flail and the shackle.

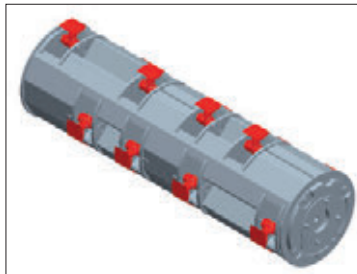

## THICK WOOD ROTOR

The thick wood rotor is available on MULTH-LONGER GII models. The 16 hammers are retractable 360° inside the rotor, which has a reconstituted frame. The rotor can cut branches up to 10 cm in diameter.



## CUTTER BAR AND SAW FOR LARGE PRUNING JOBS

Available with 4 or 5 saw blades, the cutter bar can cut branches up to 18 cm in diameter. The cutter bar can also be fitted with standard or reinforced saw blades for landscape maintenance. The 2.20 m lopper can cut branches up to 10 cm in diameter.



	EP 5050 P	EP 5050 SP	EP 5050 PA	EP 5050 SPA
<b>KINEMATICS</b>				
Horizontal reach (m) - A	5.00	5.00	5.00	5.00
Vertical reach (m) - B	6.31	6.32	6.38	6.39
Maximum hedge height (m) - C	4.45	4.46	4.69	4.70
Ditch reach at 45° (m) - D	3.23	3.23	3.00	3.00
Embankment reach (m) - E	5.16	5.18	5.34	5.34
Minimum lateral reach (m) - I	1.52	1.54	1.44	1.44
Clearance under the main boom (m) - H	1.43	1.43	1.67	1.67
Slew angle (°)	116	116	116	116
Flail head rotation (°)	220	220	220	220
Transport height (m)	3.90	3.89	3.69	3.69
Rotor position: distance ball joint axis/rotor axis (mm) - X	-	985	-	-
Offset median plane main boom/leading line of the cutting tool (mm) Y	-	1,425	-	-
<b>WEIGHT / POWER / SPEED</b>				
Machine weight (kg)	1,350	1,450	1,450	1,550
PTO speed (min <sup>-1</sup> )	540	540	540	540
Min. tractor power (hp)	80	80	80	80
Min. tractor weight (t)	4	4	4.5	4.5
<b>TRANSPORT HITCH</b>				
Automatic hitch bar + 2 stabilisers with universal joints	◆	◆	◆	◆
Hitching lugs	◇	◇	◇	◇
Hitching frame	◇	◇	◇	◇
STABLINK quickfit frame	◇	◇	◇	◇
<b>CONTROLS</b>				
Four-function electric proportional joystick	◆	◆	◆	◆
Electronically-controlled floating head	◆	◆	◆	◆
Electronically-controlled lift float	◆	◆	◆	◆
Electronically-controlled two-way rotor rotation	◇	◇	◇	◇
Emergency stop	◆	◆	◆	◆
Automatic arm break-back	◇	◇	◇	◇
Control armrest	◇	◇	◇	◇
<b>HYDRAULICS</b>				
Air-cooled radiator	◆	◆	◆	◆
Exchange capacity (kW)	12	12	12	12
Oil filtration	Intake filter and pressure			
Tank capacity	80	80	80	80
<b>ROTOR CIRCUIT</b>				
Rotor pump type	Gear pump and motor with aluminium body			
Hydraulic flow rate/pressure	104 litres at 215 bars			
<b>MOVEMENT CIRCUIT</b>				
Movement pump type	Gear pump with aluminium body			
Hydraulic flow rate/pressure	22 litres at 200 bars			
<b>FLAIL HEAD</b>				
Rotor drive	Two cog-type Vbelts			
Working width (m)	1.20	1.20	1.20	1.20
Type and number of flails on standard rotor	60 KUHN BROAD Yflails on 14 mm shackles			
Rotor rotation speed (min <sup>-1</sup> )	2,870	2,870	2,870	2,870
Sensor roller	PRO version with removable ends - 140 mm diameter			
<b>EQUIPMENTS</b>				
Front protector for brush clearing ❶	◇	◇	◇	◇
Utility Kit (tool box, box for logbook, hand washer, etc.) ❷	◇	◇	◇	◇
Adjustable grass hood ❸	◇	◇	◇	◇
Wood rotor 16 hammers jointed on 360°	-	-	-	-
2.20 m cutter bar	◇	◇	◇	◇
Four-blade saw (2.05 m)	◇	◇	◇	◇
Support for 2 triangular panels	◇	◇	◇	◇

◆ As standard ◇ Optional equipment - Not available

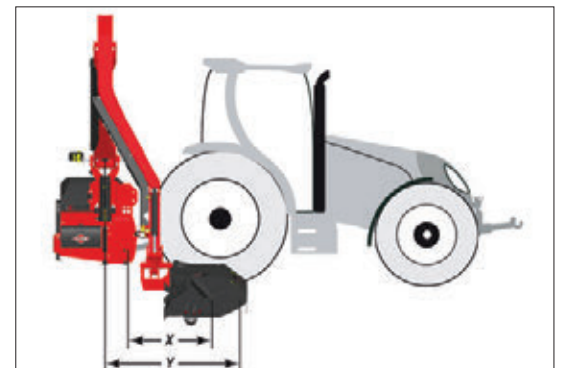
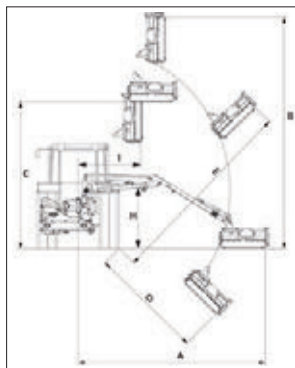



EP 5057 P      EP 5557 P      EP 5557 SP      EP 5757 SPA

<b>KINEMATICS</b>				
Horizontal reach (m) - A	5.00	5.50	5.50	5.70
Vertical reach (m) - B	6.37	6.86	6.86	6.79
Maximum hedge height (m) - C	4.79	5.32	5.32	5.50
Ditch reach at 45° (m) - D	3.11	3.53	3.53	3.63
Embankment reach (m) - E	5.24	5.73	5.73	5.88
Minimum lateral reach (m) - I	1.71	1.67	1.67	1.80
Clearance under the main boom (m) - H	1.44	1.45	1.45	1.65
Slew angle (°)	116	116	116	116
Flail head rotation (°)	240	240	240	240
Transport height (m)	3.58	3.89	3.89	3.80
Rotor position: distance ball joint axis/rotor axis (mm) - X	-	-	985	985
Offset median plane main boom/leading line of the cutting tool (mm) Y	-	-	1,425	1,425
<b>WEIGHT / POWER / SPEED</b>				
Machine weight (kg)	1,475	1,500	1,550	1,695
PTO speed (min <sup>-1</sup> )	540	540	540	540
Min. tractor power (hp)	80	80	90	90
Min. tractor weight (t)	4	4.5	4.5	5
<b>TRANSPORT HITCH</b>				
Automatic hitch bar + 2 stabilisers with universal joints	◆	◆	◆	◆
Hitching lugs	◇	◇	◇	◇
Hitching frame	◇	◇	◇	◇
STABLINK quickfit frame	◇	◇	◇	◇
<b>CONTROLS</b>				
Four-function electric proportional joystick	◆	◆	◆	◆
Electronically-controlled floating head	◆	◆	◆	◆
Electronically-controlled lift float	◆	◆	◆	◆
Electronically-controlled two-way rotor rotation	◇	◇	◇	◇
Emergency stop	◆	◆	◆	◆
Automatic arm break-back	◇	◇	◇	◇
Control armrest	◇	◇	◇	◇
<b>HYDRAULICS</b>				
Air-cooled radiator	◆	◆	◆	◆
Exchange capacity (kW)	12	12	12	12
Oil filtration	Intake filter			
Tank capacity	80	80	80	80
<b>ROTOR CIRCUIT</b>				
Rotor pump type	Gear pump and motor with cast iron body			
Hydraulic flow rate/pressure	110 litres at 230 bars			
<b>MOVEMENT CIRCUIT</b>				
Movement pump type	Gear pump with cast iron body			
Hydraulic flow rate/pressure	35 litres at 220 bars			
<b>FLAIL HEAD</b>				
Rotor drive	Two cog-type Vbelts			
Working width (m)	1.20	1.20	1.20	1.20
Type and number of flails on standard rotor	60 KUHN BROAD Y-flails on 14 mm shackles			
Rotor rotation speed (min <sup>-1</sup> )	2,970	2,970	2,970	2,970
Sensor roller	PRO version with removable ends - 140 mm diameter			
<b>EQUIPMENTS</b>				
Front protector for brush clearing ❶	◇	◇	◇	◇
Utility Kit (tool box, box for logbook, hand washer, etc.) ❷	◇	◇	◇	◇
Adjustable grass hood ❸	◇	◇	◇	◇
Wood rotor 16 hammers jointed on 360°	◇	◇	◇	◇
2.20 m cutter bar	◇	◇	◇	◇
2.50 or 2.50 m tree pruning cutter bar (4 or 5 saw blades)	◇	◇	◇	◇
Support for 2 triangular panels	◇	◇	◇	◇

◆ As standard    ◇ Optional equipment    - Not available

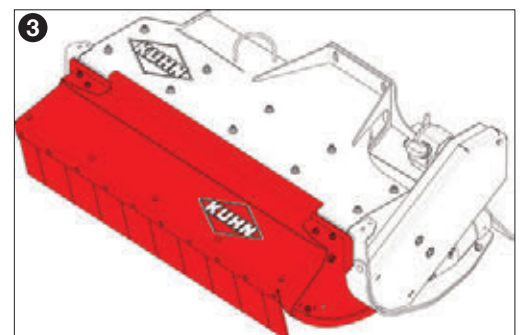
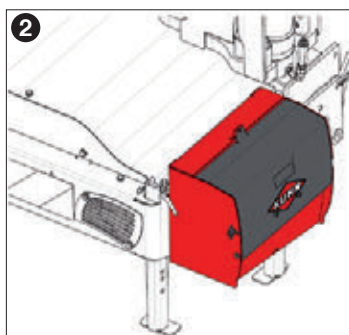
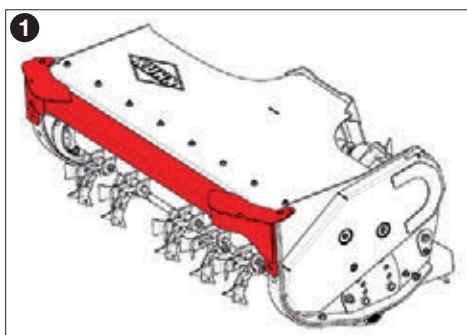



# ALL THE KUHN HEDGE AND GRASS CUTTERS!

Horizontal reach	Rotor circuit power	Recommended use	Minimum tractor weight and power	Branch cutting and shredding			Range			
				Mixed rotor for branches Ø < 3 cm	Mixed rotor for branches Ø < 5 cm	Wood rotor for branches Ø < 10 cm				
4.20 m	25 kW (34 hp)	Up to 100 hrs/year	3 tonnes 70 hp				AGRI-LONGER			
4.70 m				✓						
4.70 m										
4.87 m	32 kW (44 hp)	Up to 250 hrs/year	3.5 tonnes 70 hp	✓	✓		MULTI-LONGER GI			
5.00 m	37 kW (51 hp)	Up to 500 hrs/year	4 to 4.5 tonnes 80 hp	✓			POLY-LONGER			
5.00 m	41 kW (57 hp)	Up to 800 hrs/year	4 to 5 tonnes 80 to 90 hp	✓			MULTI-LONGER GII			
5.50 m								✓		✓
5.70 m										
5.10 m	59 kW (80 hp)	Up to 1500 hrs/year	4.5 to 6.5 tonnes 100 to 120 hp	✓			PRO-LONGER GII			
5.60 m										
5.70 m								✓		✓
6.10 m										
7.40 m										





Control type	Arm on pivot	Models					
		Compass kinematics			Parallelogram kinematics		
		Straight arm	Semi-leading arm OPTview	Telescopic arm	Straight arm	Semi-leading arm OPTview	Leading arm
Cable control (T)		T 4234 M					
Cable control (T)		T 4734 M					
Electric joystick (E)		E 4734 M					
Cable control (T)	☑	T 4844 P					
Low pressure joystick (ET)		HE 4844 P					
4-function electric proportional joystick (EP)	☑	EP 5050 P	EP 5050 SP		EP 5050 PA	EP 5050 SPA	
4-function electric proportional joystick (EP)	☑	EP 5057 P					
		EP 5557 P	EP 5557 SP				
						EP 5757 SPA	
4-function electric proportional joystick (EP)	☑	EP 5183 P					
		EP 5683 P	EP 5683 SP				
						EP 5783 SPA	EP 5783 LPA
				EP 6183 TP		EP 6183 SPA	
				EP 7483 TP			

## TO FIND OUT MORE:



Website  
[www.kuhn.com](http://www.kuhn.com)



# TO COMPLETE THE WORK OF YOUR HEDGE AND GRASS CUTTER:



1



2



3



4



5



6

1. Verge shredders from 1.61 to 2.49 m - 2. Roadside mowers from 1.60 to 2.30 m in rear or front version - 3. Special shredders for mini-tractors and vertical shaft shredders - 4. Shredders for slope tractors from 1.75 to 2.10 m - 5. Salt/sand spreaders - 6. Range of green space sprayers.



## KUHN PARTS

DESIGNED AND MANUFACTURED TO RIVAL TIME



KUHN foundries and forge as well as a high-level manufacturing process allow the production of spare parts to defy time. You can truly rely on our know-how and our genuine parts. Farmers benefit from our client support and logistics services via any KUHN PARTS warehouse, which provide quick and reliable repair solutions in cooperation with your nearest authorized KUHN dealer.



For more information about your nearest KUHN dealer, visit our website [www.kuhn.com](http://www.kuhn.com)

 <p><a href="http://www.kuhn.com">www.kuhn.com</a></p>	<p>Your KUHN dealer</p>
---	-------------------------

**KUHN FARM MACHINERY (U.K.) LTD**  
Stafford Park 7 - GB TELFORD/ SHROPS TF3 3BQ

**KUHN FARM MACHINERY PTY. LTD**  
313-325 Foleys Road - Deer Park, VIC, 3023 - AUSTRALIA

**KUHN NORTH AMERICA, INC.**  
1501 West Seventh Avenue - P.O. BOX 0167 - Brodhead, WI 53520 - USA

Some machines have a considerable weight. Respect the tractor gross vehicle weight rating, its lift capacity and maximum load per axle. The tractor front axle load must always reach minimum 20% of the tractor net weight. Our material is produced in accordance with the European Machinery Directive in the member states of the European Union. In countries outside the E.U., our machinery complies with the safety regulations set by the country concerned. Some safety devices may have been removed from our leaflets in order to clarify the illustration. Under no circumstances should the machine be operated without the necessary safety devices in place (as specified by the assembly instructions and operators manual). We reserve the right to change any designs, specifications or materials listed without further notice. Machines and equipment in this document can be covered by at least one patent and/or registered design. Trademarks cited in this document may be registered in one or several countries.

Also find KUHN on    